

Specifications

Video Performance*

Video Input Impedance	75 ohm (balanced)
Video Input Voltage	1 V p
Video Connector	BNC
Frequency Response	10 Hz to 7 MHz (3 dB)
Signal to Noise Ratio	62 dB as per RS250C
Differential Gain (-20°C to +70°C)	<4%
Differential Gain (-30°C to +85°C)	<7%
Differential Phase (-20°C to +70°C)	<4°
Differential Phase (-30°C to +85°C)	<7°
Field Tilt	<2%
Luminance	
Non-Linearity (-20°C to +70°C)	<4%
Luminance	
Non-Linearity (-30°C to +85°C)	<7%

Optical Performance

Single mode - Core Diameter	8 - 10u
Optical Connector	ST, FC, SC
Transmitting Light Source	Laser 1310 nm
Optical Power Output	-8 dBm (+/- 2 dBm @ -30 °C to +85 °C)
Receiving Wavelength	1550 nm
Data Receiver Sensitivity*	- 35 dBm

Data Interface

Data Interface	RS-422 Bi-directional – 4 wire
Data Rate*	Up to 200Kb/s

* measured with 144S or 244S video receiver unit as per RS-250C @ 1km fiber cable

Operating Temperature	-30°C to +85°C
Dimensions	6.75”(172mm) x 4.95”(126mm) x 1.4”(36mm)
Power Requirements	12V AC or DC @ 300mA; 24VAC @ 200mA

144S-VT/DX-M1(-MD)

Fiber Optic Video Transmitter & 2Ch. RS-422 Data Transceiver

Singlemode

Single Fiber Operation

Elcommtech Corp.
2620 Ocean Parkway, Suite 4H
Brooklyn NY 11235
(718)743-2869 Fax: (718)648-3642
E-Mail: sales@elcommtech.com
Internet: <http://www.elcommtech.com>

Introduction :

The Elcommtech 144S-VT/DX-M1 forms part of a singlemode, single fiber, video and data fiber optic transmission system. Using frequency modulation and operating as a dual window 1310/1550nm single fiber unit, the 144S-VT/DX-M1 provides the following facilities in a 170mm x 126mm x 34mm free standing module.

Optical Transmitter for : Composite Video signal & 2 x RS-422 Data Channels
 Optical Receiver for : 2 x RS-422 Data Channels

Model 144S-VT/DX-M1-MD contains an additional noise filter in the input data channel.

Indicators :- All indicators are located on the top of the module.

Indicator		
Power	off	The unit is not powered
	green	Power connected
Video Input	off	No video input or insufficient video signal present
	green	Composite Video signal present
Data Link	off	No received optical signal present
	green	Optical signal received
Data Tx1	off	No data signal present at the optical transmitter Ch.1 input
	red	Data signal is present at the optical transmitter Ch.1 input
Data Rx1	off	No data signal present at the optical receiver Ch.1 output
	green	Data signal is present at the optical receiver Ch.1 output
Data Tx2	off	No data signal present at the optical transmitter Ch.2 input
	red	Data signal is present to the optical transmitter Ch.2 input
Data Rx2	off	No data signal present at the optical receiver Ch.2 output
	green	Data signal is available at the optical receiver Ch.2 output

Data Connector Pinouts

Data Port - RJ45 Modular Receptacle

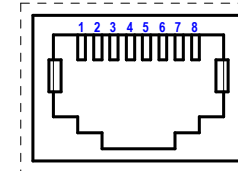

RS-422 Data Port Connector

RS-422	Tx1 (IN1)	Rx1 (OUT1)	Tx2 (IN2)	Rx2 (OUT2)
DATA SIGNAL +	1	3	5	7
DATA SIGNAL -	2	4	6	8

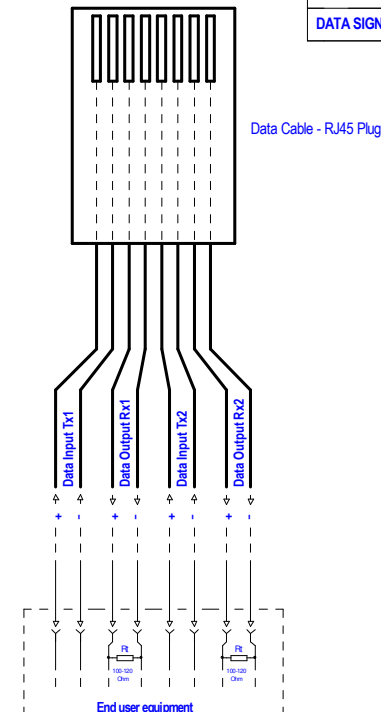

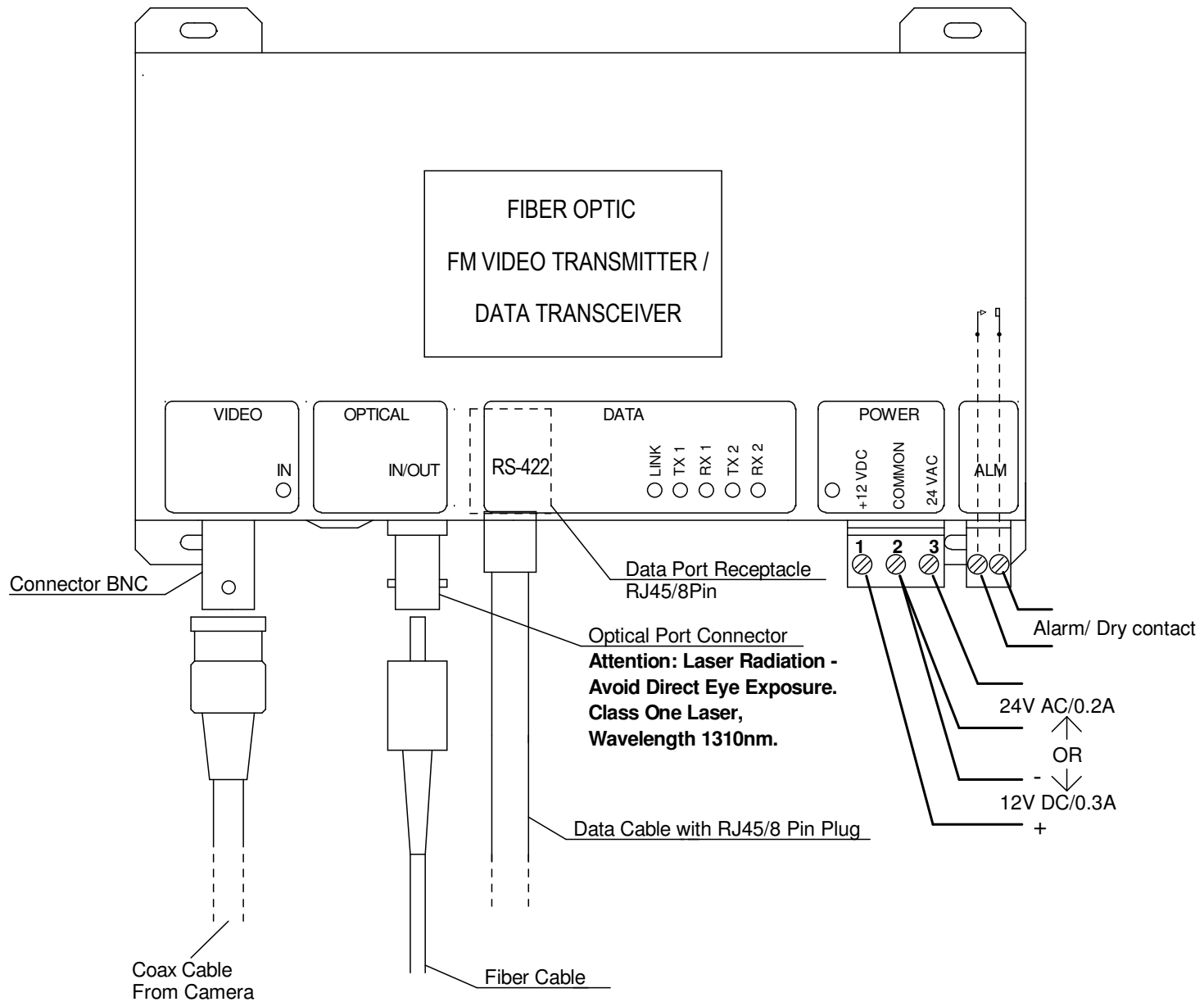

144S-VT/DX-M1 Video Transmitter / Data Transceiver Connections

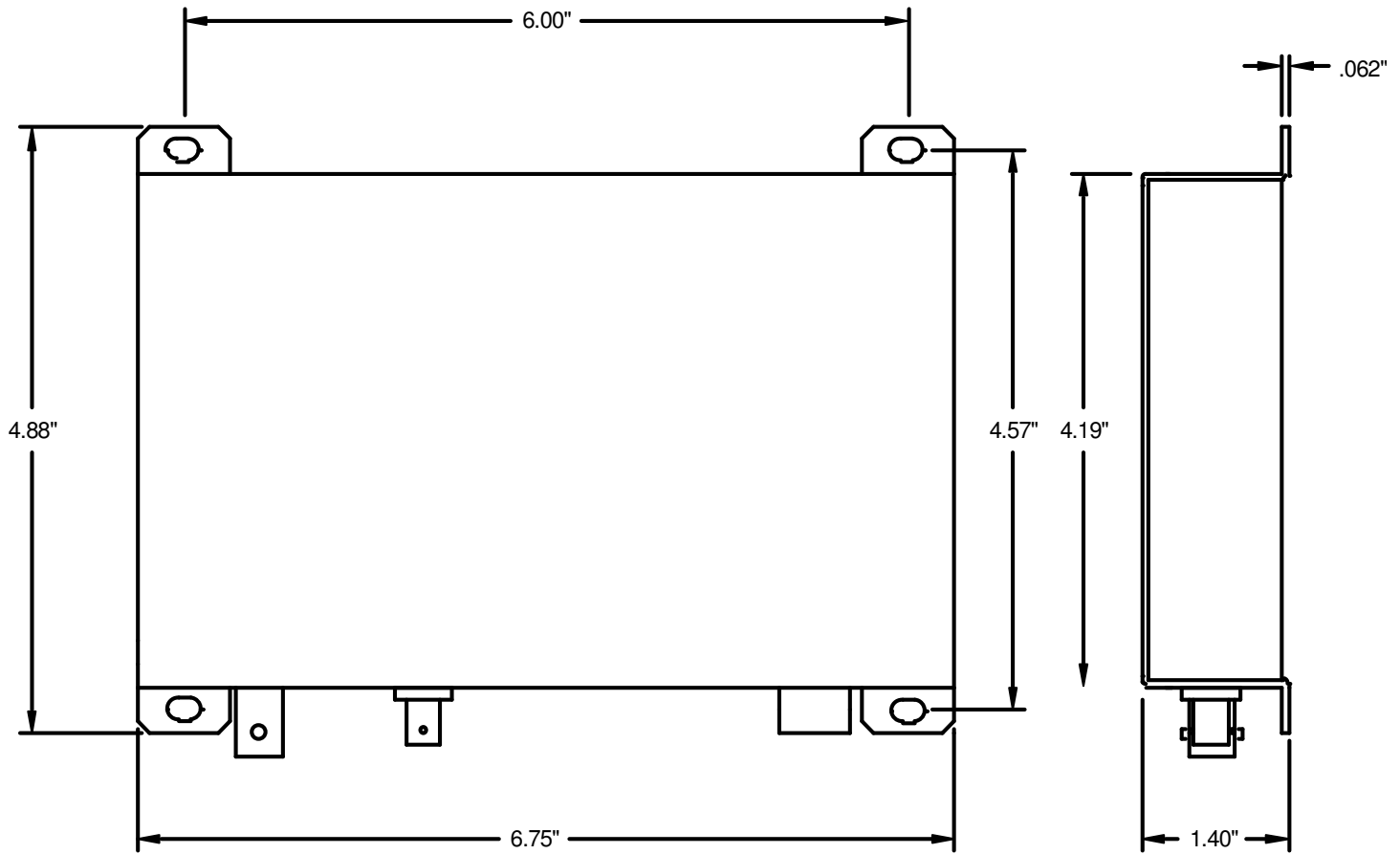

Installation Drawing

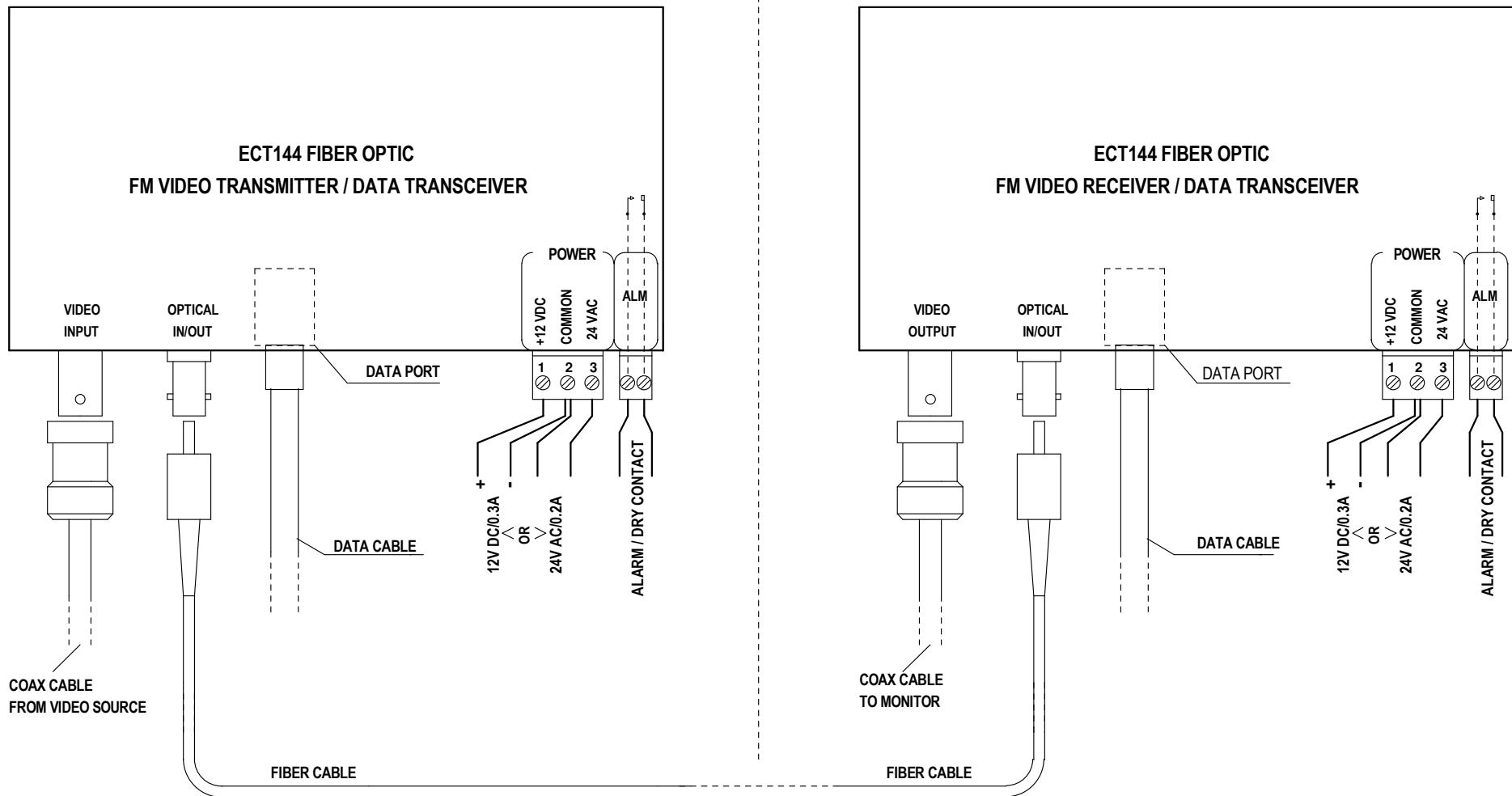

ECT144 Video & Data Link
 Connection Diagram

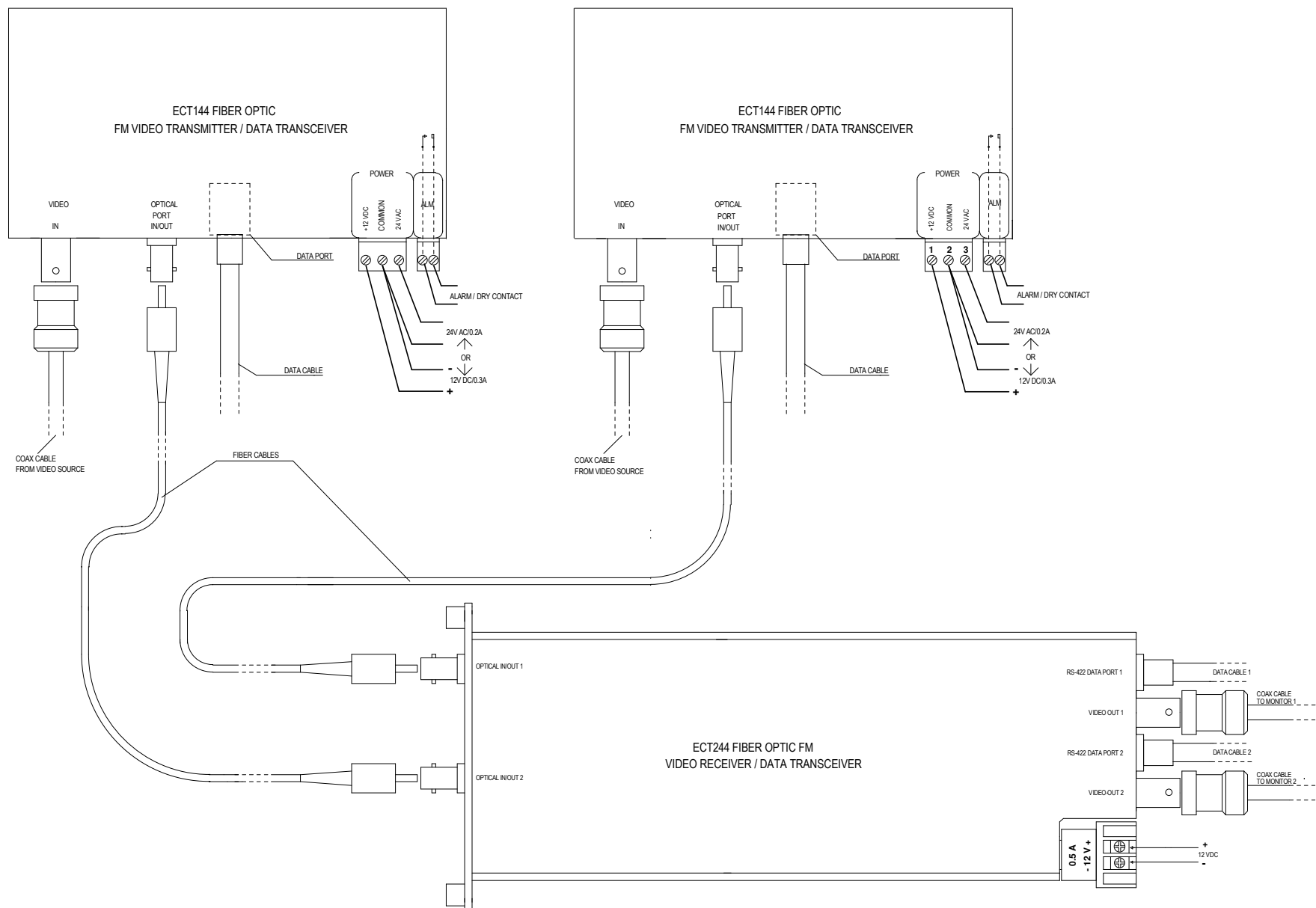

**ECT144/244 Video & Data Link
Connection Diagram**

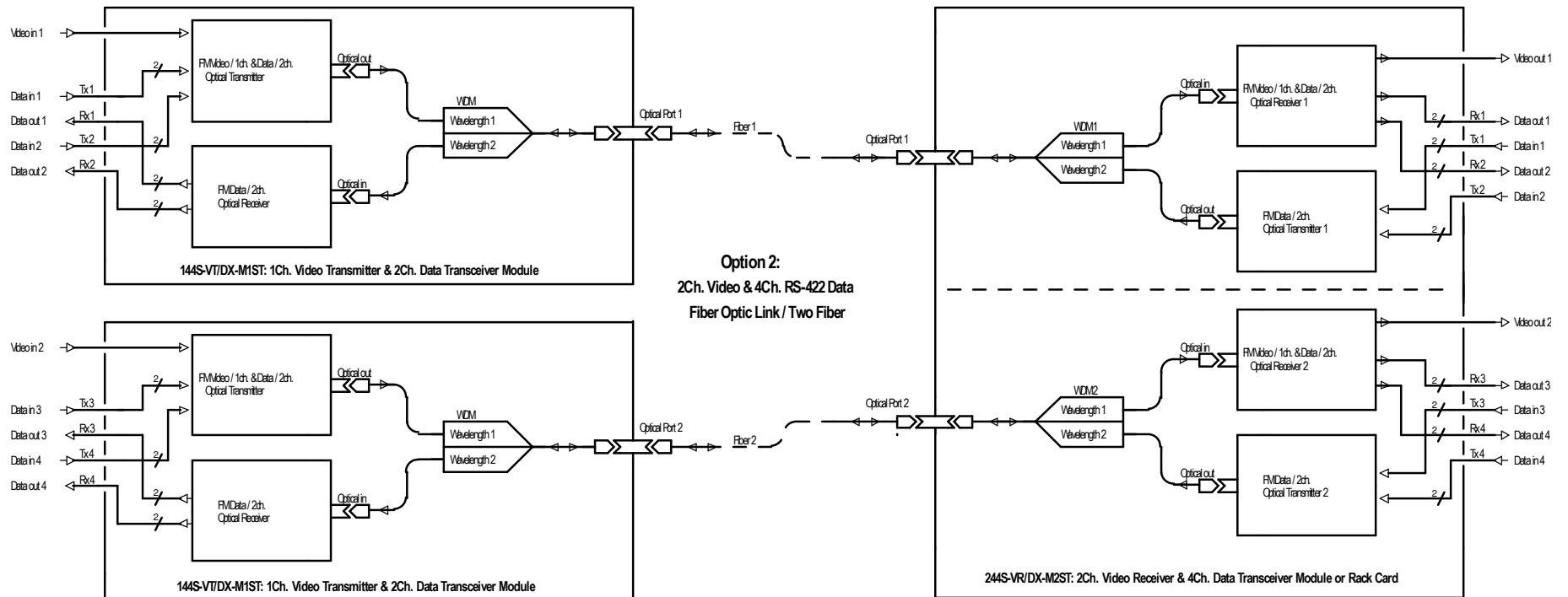
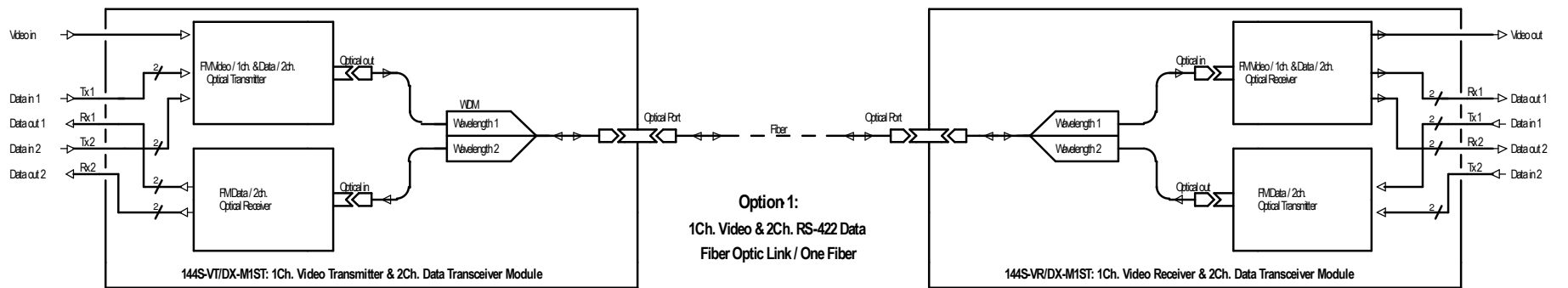

**Video & RS-422 Data Fiber Optic Link Configurations
Block Diagram**

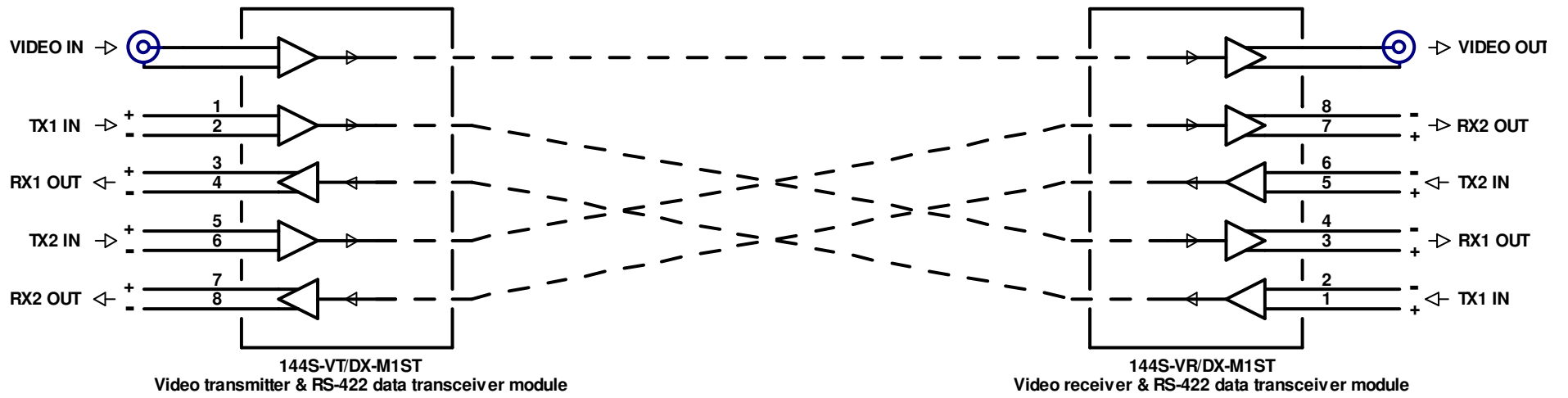

**ECT144 Fiber Optic FM Video & RS-422 Data Optical Link
Communication Logical Diagram**